

Connecting the GROM(8BJ-JC92) ECU to the ENIGMA SemiFull Bluetooth version

Supported models of this manual

ENIGMA type ENIGMA SemiFull (SF2339RTF)

Vehicle type HONDA GROM (8BJ-JC92 1100001-1199999/1200001-)

This ENIGMA SemiFull can not connect the GROM(2BJ-JC92) .

Installation should be done in a safe place.

A basic knowledge of GROM(8BJ-JC92) maintenance is necessary.

There is the ECU in the cowl on the lower left side of the seat.

Remove the seat cover, the gas tank cover on the left side.

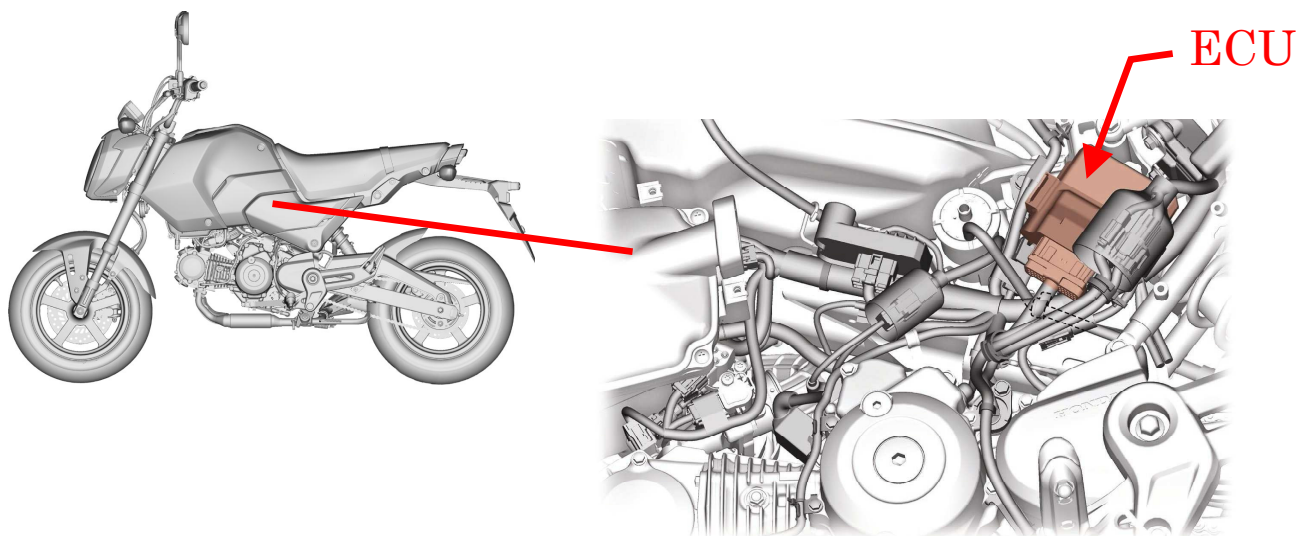

After removing the ECU to the rubber mount, disconnect the ECU from the body coupler and connect the ENIGMA SemiFull coupler between the ECU and the body coupler.

Attach the the ECU to the rubber mount.

Place the ENIGMA SemiFull in the gas tank cover.

This body must be secured against excessive vibration and rainwater.

Connect the wires with Y-terminal terminal that branches out from the middle of the ENIGMA SemiFull RTF to the GND side of the battery.

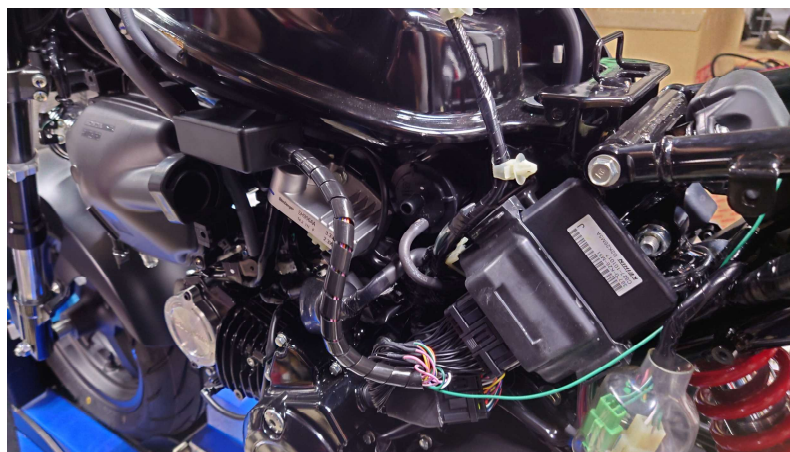

- **The wire with the Y terminal must be connected to the GND side of the battery or to the frame.**
- The White wire is a pit lane switch service and is not to be connected to the ECU. When you do not want to use this function, please tip of the wire is insulated with tape so as not to short against the metal part.
- The Gray/Red wire is a wire for the MAP changeover switch and is not to be connected to the ECU. When you do not want to use this function, please tip of the wire is insulated with tape so as not to short against the metal part.
- **The purple line is the service output line.** The ENIGMA SemiFull will output 5V each crank rotation (or Once every two crank revolutions). Most commercially available digital tachometers are supported. Exact values will be displayed if these cables are connected. They are useful to various applications. Do not short-circuit by taping when there is no need.
- Please use the **GROM (8BJ-JC92)** dedicated ENIGMA Semifull PC software. Other Vehicle, Other ENIGMA dedicated PC softwares, cannot be used.
Please use the ENIGMA Semifull dedicated app for the iOS/Android version of the app.
Download the **GROM (8BJ-JC92)** dedicated ENIGMA Semifull app from the model selection screen in the app. Other Vehicle dedicated apps cannot be used.
- The ENIGMA SemiFull operating software can be downloaded free from our website.

<http://www.dilts-japan.com>

Installation of the pit lane limiter switch

"White wire" that has come out from ENIGMA Semifull is the wiring for the pit lane limiter switch installation.

Pit lane limiter to the rotation of the constant engine speed to control the speed only when the external switch ON

You control. Do those who want to use this feature by performing the following tasks.

In general, to buy a handle mounting switch, which is commercially available, it should be placed in easy-to-use position.

(If you are installing to handle and place easy to operate location does not interfere with operation)

Switch is common thing that cuts in the "OFF" position to connect with the "ON" position.

Switch is not suitable to be connected only when you press. be careful.

Connect the White line the installation of the switch is out of the ENIGMA Semifull when finished.

Connect the White line to one of the terminals of the switch. The other is connected to ensure that "body earth".

The most reliable of is to connect to the negative battery. Circuit will be burned down and unavailable when connecting to the positive wrong. Never done.

This completes the installation of pit lane limiter switch with more work

When you do not want to use the pit lane limiter function, please tip of the wire is insulated with tape so as not to short against the metal part.

Installation of the MAP changeover switch

"Gray/Red wire" that has come out from ENIGMA Semifull is the wiring for the MAP changeover switch installation. You can instantly switch between a two maps with the MAP changeover switch.

Do those who want to use this feature by performing the following tasks.

In general, to buy a handle mounting switch, which is commercially available, it should be placed in easy-to-use position. (If you are installing to handle and place easy to operate location does not interfere with operation.)

Switch is common thing that cuts in the "OFF" position to connect with the "ON" position.

Switch is not suitable to be connected only when you press. be careful.

Connect the Gray/Red line from the ENIGMA Semifull when finished the installation of the switch.

Connect the Gray/Red line to one of the terminals of the switch. The other is connected to ensure that "body earth". **The most reliable of is to connect to the negative battery. Circuit will be burned down and unavailable when connecting to the positive wrong. Never done.**

This completes the wiring for the MAP changeover switch with more work.

When you do not want to use the wiring for the MAP changeover function, please tip of the wire is insulated with tape so as not to short against the metal part.

When switching maps, Be sure to transfer the data to both maps before starting to avoid engine trouble.